

STEDMAN

"H" Series Cage Mill

*Efficiently crush, pulverize, blend and mix
abrasive or non-abrasive wet, sticky or dry materials*

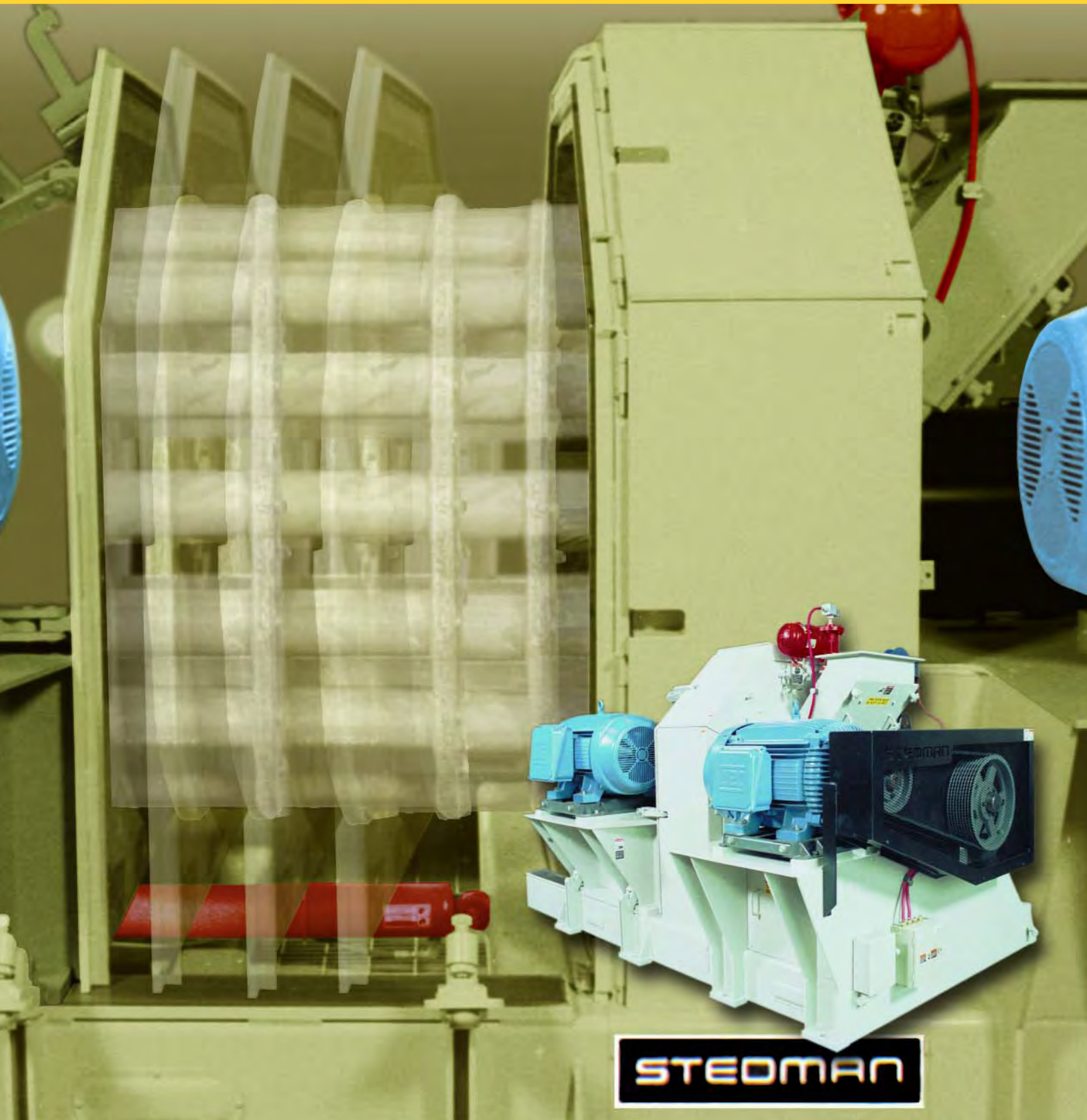

STEDMAN

Stedman "H" Series Cage Mill

Stedman's "H" Series Cage Mill can crush, grind, pulverize, blend and mix abrasive or non-abrasive — even wet, sticky or dry materials — more efficiently than any competitive machine. They also provide a finer, more uniform grind. The "H" mill is engineered and built to operate at or near peak efficiency for a longer period of time, and continues to provide a greater return on your capital investment over its extended useful life.

- Four standard "H" mill sizes provide capacities up to 240 tons-per-hour of crushed product.
- Quick-opening feature for periodic inspection and maintenance.
- Compact, unitized construction, occupies up to 45% less floor space.
- Positively seals the housing.
- Provide optimum utilization of crushing components.



Heaters (shown with guards removed) are installed on the "H" Mill housing to retard build-up of wet material.

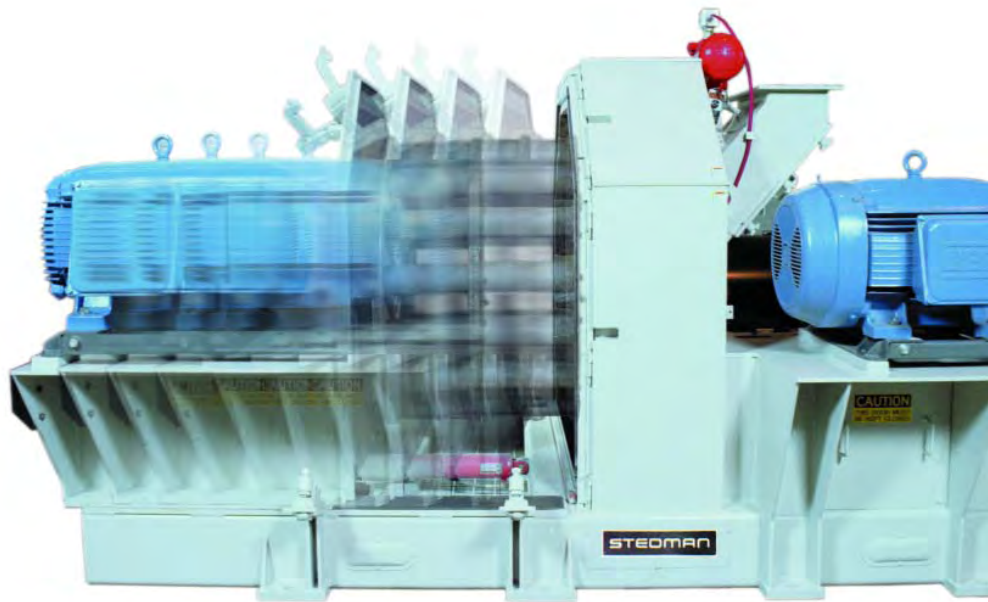

Quick-Retraction

- Hydraulically-operated, quick-opening retractor provides rapid access to crushing components for inspection or change-out.
- After quick-release clamps are loosened, operator depresses push button to activate hydraulic pump motor.
- Activate control lever located on hydraulic power unit to back off retractable half of mill, exposing cages and other replaceable parts.
- The hopper side pedestal is an integral part of the rectangular steel base weldment.
- Quick opening feature allows prescheduling of downtime for parts change out based on regular inspections.
- Since motors are integral to mill pedestals and common base, all service described is done without moving or disturbing motors, V-belt drives, or belt guards.
- Inspection requires about five minutes, complete change-out of wear components as little as one hour, or less, compared to 10-hours or more on other mills.
- Powered automatic retraction also ensures positive axial alignment of all rotating members at each re-engagement of mill halves.
- Limit switches stop retraction automatically; safety interlocks prevent operation of retractor when power is on to either motor.



Air Cannons are mounted at the intake and discharge to help prevent build up of wet material.



Two-piece housing is secured by simple toggle clamps, retractable pedestal by compound toggle clamps, as shown. Stedman-furnished, removable handle actuates both types of clamps. When not in use, handle is stored conveniently in base of mill.

New design, more efficient cages

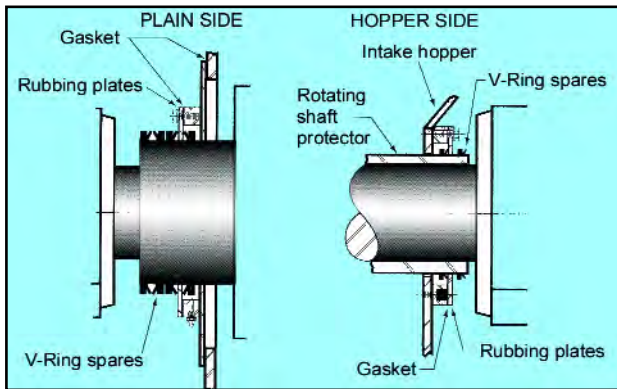

Positive Shaft Seals

- Both shafts are sealed with Stedman field-proven shaft seals where they pass through the housings.
- Seals are positive face-contact type, V-ring design, with nitrile rubber seal rings.

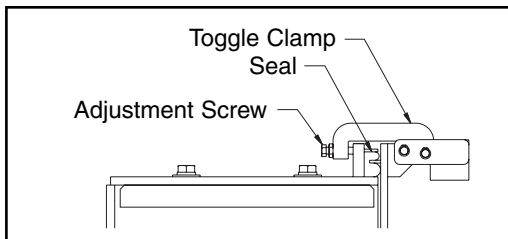

Protected Sealing

- One-piece/single-joint housing is *positively sealed* against dusting by unique Stedman channel construction elastomer seal.
- Seal consists of a steel lip which engages deeply into and compresses a large cross-sectional area of low durometer gasket.
- Inspection door features same protected seal arrangement.

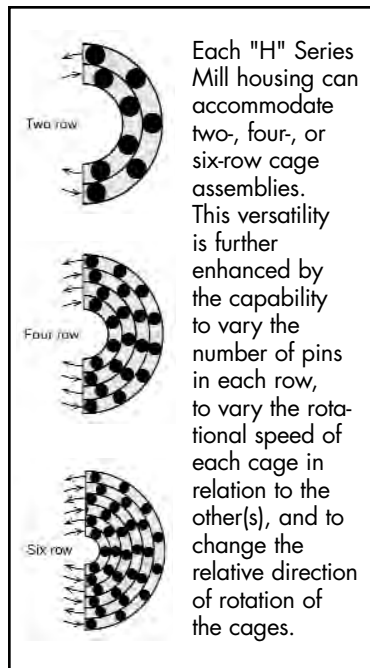

- All-new cage configuration features expanded vertical clearance between cage rows; relieves attrition grinding; provides for controlled stages of true impact crushing action.
- Stedman's exclusive, automatic hard-surfacing process, combined with increased cage clearance, provides superior wear-resistance for significantly longer component life.
- Round cage pins (sleeves) make cage rotation reversal possible resulting in 60% more metal utilization.
- Round pin design also drastically reduces "fan-effect" and extraneous air movement caused by rotating cages, minimizing no-load horsepower requirements; energy saving result.
- Unlike crushers that depend on close clearances for shearing that will experience a change in the gradation during the wear life, with a cage mill there is no noticeable change in gradation throughout the life of the sleeves. This will enhance the efficiency of the equipment operating downstream from the cage mill, for example, screens and extruders.

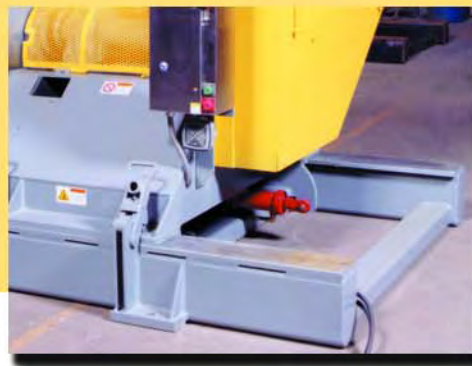

Retracting pedestal utilizes a hydraulic ram arrangement that provides rapid access to crushing components for inspection or change-out. Hydraulic pump included with all models.

Round cage pins do not materially change their basic configuration during their operating life. Therefore, product variation due to any such change is minimized.

H-40, 48, 54 & 62 Multi-cage Mill

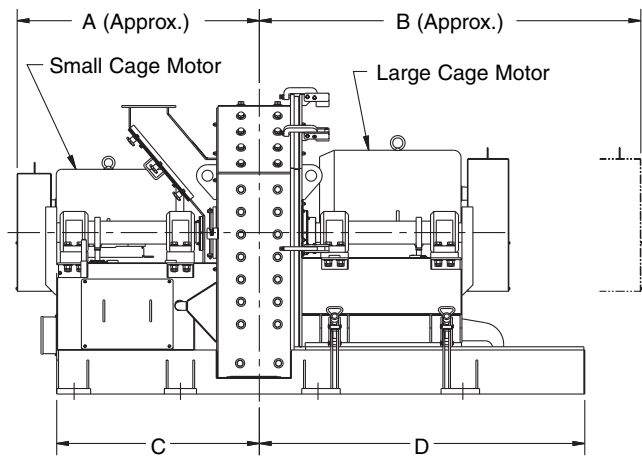
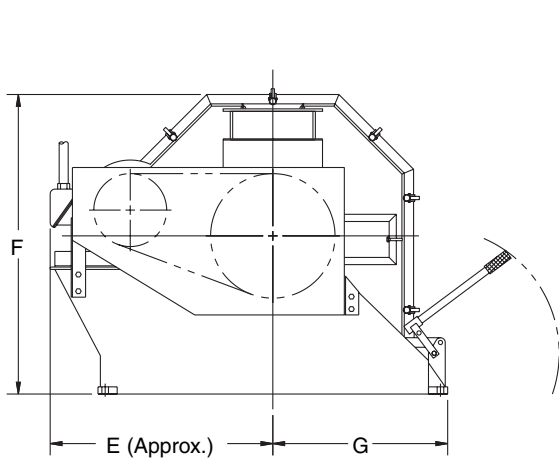

Dimensions in inches (millimeters)

Mill Size	A	B	C	D	E	F	G
H-40	52 (1321)	79 (2007)	42½(1080)	69½(1765)	52⅛(1324)	62½(1588)	36(914)
H-48	61½(1562)	91½(2324)	50½(1283)	79 (2007)	58 (1473)	71⅝(1819)	40⅝(1032)
H-54	67¼(1708)	103¼(2623)	55¼(1403)	88½(2248)	60 (1524)	79⅝(2022)	44⅝(1133)
H-62	88 (2235)	132 (3353)	74¼(1810)	111 (2819)	90 (2286)	96¼(2445)	55¼(1403)

Maximum Capacities

Mill Size	Tons per Hour		Maximum Feed Size	Approx. Max. Hp		Approx. Weight Lbs.
	2-Row	4-Row		Small Cage	Large Cage	
H-40	35	20	1½"	50	75	15,000
H-48	70	35	2"	100	150	20,000
H-54	150	75	2½"	200	250	26,000
H-62	240	110	2½"	300	400	52,000

NOTE: Capacities vary widely, dependent upon feed size, desired product size, weight per cu. ft. of material being reduced.
CAUTION: Do not use these dimensions for construction purposes.

Feeds and Gradations

Maximum feed sizes for "H" Series Mills range from 1-inch for the 40-inch mill, up to five inches in diameter for the 62-inch mill. (Note: mill size is indicated by nominal large cage diameter.)

The "H" mill is capable of producing a variety of product gradations, which can be easily altered by changing the speed of the mill. Final crushed product sizes range from

½-inch x 20 mesh on the coarse side, down to pulverized materials as fine as 80% passing 200 mesh.

We invite you to send a sample of your feed material for evaluation in Stedman's Customer Service Testing Facility. All tests will be run in a full-size production model "H" mill. Contact Customer Service Testing at the address below for more details.



www.stedman-machine.com

STEDMAN • P.O. Box 299 • Aurora, IN 47001 • Toll free: 800-262-5401
Fax: 812-926-3482 • Email: sales@stedman-machine.com